

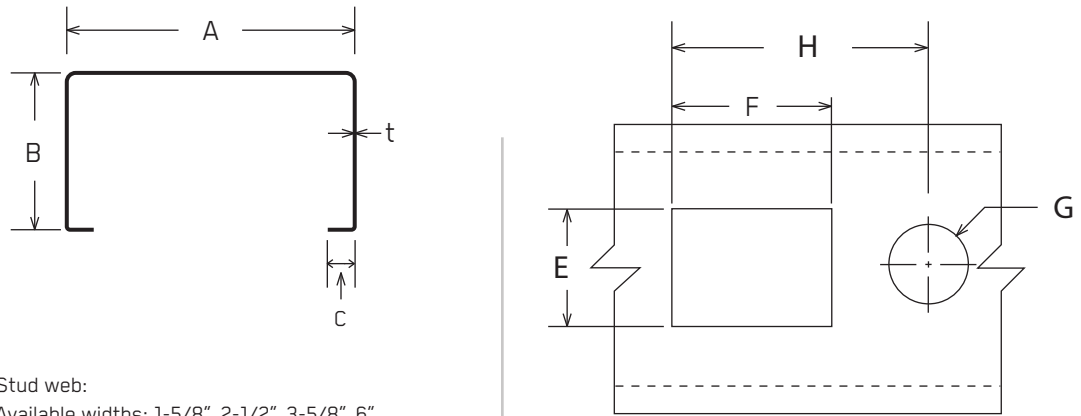

NON-LOAD BEARING INTERIOR STUD

SPECIFICATION SHEET



A: Stud web:
 Available widths: 1-5/8", 2-1/2", 3-5/8", 6"
 Dimensions as specified in standard ASTM C645-18
 Minimum protective coating: G40 (C653-20)

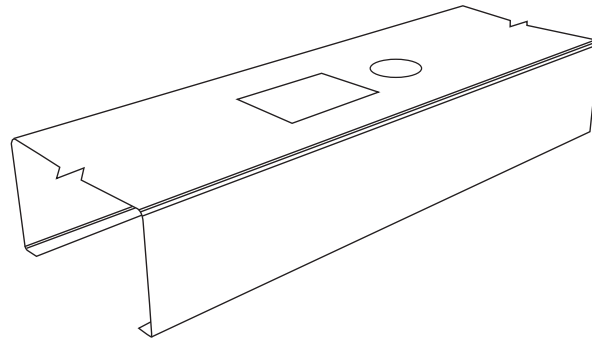

Stud in compliance with standards:
 CAN/CSA S136-16 / ASTM A653-20, C645-18, C754-20 / AISI S220-2015

LEGEND:

- A = Web (in)
- B = Flange (in)
- C = Lip (in)
- t = Minimum thickness of steel design coating not included (in)

CSSBI NOMENCLATURE (AISI-S201-17)

Example: CSSBI/ICTAB 61-MG 362S125-18 33 KSI G40 XXXX
 362 A: 3-5/8 = 3.625
 S Stud type: S = Stud T = Track F = Furring channel ST = Slotted track U = Channel
 125 B: 1-1/4 = 1.250
 18 t: 18 = 18 Mils

Québec
 418-871-8088
 800-871-5818
 Boucherville
 450-655-5100



May 2022

NON-LOAD BEARING INTERIOR STUD

CONFIGURATIONS

A* (in)	B (in)	t (Mils)	C (in)	E** (in)	F (in)	G (in)	H (in)
1-5/8 (162)	1-1/4 (125)	18	3/16	3/4	2	3/4	3
2-1/2 (250)	1-1/4 (125)	18	3/16	3/4	2	3/4	3
3-5/8 (362)	1-1/4 (125)	18	3/16	1-1/2	2	1-3/8	3-1/4
6 (600)	1-1/4 (125)	18	3/16	1-1/2	2	1-3/8	3-1/4

*other dimensions on request

**AISI S220-2015 : Maximum 50% of "A"

Table of permissible elevations on composite walls with 5/8" gypsum panels on each side as described in ASTM C754-20

Stud	Deflection limit	With studs 12 in. O.C. Lateral load			With studs 16 in. O.C. Lateral load			With studs 24 in. O.C. Lateral load		
		5 psf.	7.5 psf.	10 psf.	5 psf.	7.5 psf.	10 psf.	5 psf.	7.5 psf.	10 psf.
162S125-18 (1-5/8)	L/120	13-0f	10-8	9-3f	11-3	9-3f	8-0f	9-3f	s/o	s/o
	L/240	11-1	9-8	8-9	10-1	8-9	7-11	8-9	s/o	s/o
	L/360	9-10	8-7	7-9	8-11	7-9	s/o	7-9	s/o	s/o
250S125-18 (2-1/2)	L/120	16-4f	13-4	11-7f	14-2f	11-7f	10-0f	11-7f	9-5f	8-2f
	L/240	14-2	12-4	11-3	12-10	11-3	10-0f	11-3	9-5f	8-2f
	L/360	12-9	11-2	10-2	11-7	10-2	9-0	10-2	8-6	s/o
362S125-18 (3-5/8)	L/120	18-8f	15-3f	13-2f	16-2f	13-2f	11-5f	13-2f	10-9f	9-4f
	L/240	16-8	14-7	13-2f	15-2	13-2f	11-5f	13-2f	10-9f	9-4f
	L/360	14-7	12-9	11-6	13-3	11-6	10-4	11-6	9-11	8-11
600S125-18 (6)	L/120	23-2f	18-11f	16-4f	20-1f	16-4f	14-2f	16-4f	13-4f	s/o
	L/240	22-9	18-11f	16-4f	20-1f	16-4f	14-2f	16-4f	13-4f	s/o
	L/360	19-11	17-5	15-10	18-1	15-10	14-2f	15-10	13-4f	s/o

f= Indicates bending controls

THICKNESS

For table calculations, the standard S136-16 prescribes the thickness of the material used.

Nominal:	Thickness used - steel without protective coating for table calculations
Minimum (t):	Minimum steel thickness allowed without protective coating (95% of design)
Coating:	Protective coating applied to the steel. G40 = 0.40 oz/ft ² G60 = 0.60 oz/ft ² G90 = 0.90 oz/ft ² 1 oz/ft ² estimated 0.00168 in. total both sides (standard A653 8.1.3-20)
Measured:	Minimum measured thickness of a stud with protective coating (final product)

min (Mils)	nominal t (in)	minimum (95% nominal)	G	minimum coating oz/ft ²	(in)	Measured (in)	Grade ksi
18	0.0188	0.0179	40	0.40	0.0007	0.0186	33

CAN/CSA S136-16 : Spécification nord-américaine pour le calcul des éléments de charpente en acier formés à froid

ASTM A653-20 : "Standard Specification for Steel Sheet, Zinc-Coated (Galvanized) or Zinc-Iron Alloy-Coated (Galvanealed) by Hot Dip Process"

ASTM C645-18 : "Standard Specification for Nonstructural Steel Framing Members"

AISI S220-2015 : "North American Standard for Cold-Formed Steel Framing"

ASTM C754-20 : "Standard Specification for Installation of Steel Framing Members to Receive Screw-Attached Gypsum Panel Products"



MANUGYPSE

Québec 418-871-8088 • 800-871-5818

Boucherville 450-655-5100

May 2022